



toledo

Toledo 90 Gas
Users Guide
&
Installation Instructions

U1 228 02

Contents

<i>2 Minute Tour</i>	<i>Page 3</i>
<i>The hotplate burners</i>	<i>Page 8</i>
<i>The griddle</i>	<i>Page 8</i>
<i>The Warmer</i>	<i>Page 8</i>
<i>The grill</i>	<i>Page 8</i>
<i>The ovens</i>	<i>Page 9</i>
<i>The Handyrack</i>	<i>Page 9</i>
<i>'S' (Slow) cooking</i>	<i>Page 10</i>
<i>Oven cooking guide</i>	<i>Page 11</i>
<i>Cooking using the timer</i>	<i>Page 12</i>
<i>The clock</i>	<i>Page 13</i>
<i>Cleaning your cooker</i>	<i>Page 14</i>
<i>Moving your cooker</i>	<i>Page 16</i>
<i>Troubleshooting</i>	<i>Page 18</i>
<i>General Safety Instructions</i>	<i>Page 20</i>
<i>Installation</i>	<i>Page 22</i>
<i>Circuit Diagram</i>	<i>Page 30</i>
<i>Technical Data</i>	<i>Page 31</i>

2 Minute Tour

Be safe

You need clean fresh air - so does your cooker. Burner flames produce exhaust gases, heat and moisture. Make sure that the kitchen is well ventilated: keep natural ventilation holes open or install a powered cooker hood that vents outside. If you have several burners on or use the cooker for a long time, open a window or turn on an extractor fan. For more detail see the Installation Instructions.

We recommend you read pages 20 & 21 if you have not used a gas cooker before.

We describe some basic guidelines on how to use a gas cooker safely.

Gas and Electricity on

Make sure that the gas supply is turned on and that the cooker is wired in and switched on.

The cooker needs electricity.

Peculiar smells

When you first use your cooker it may give off a slight odour. This should stop after a little use.

HOTPLATE BURNERS *More about the burners on page 8*

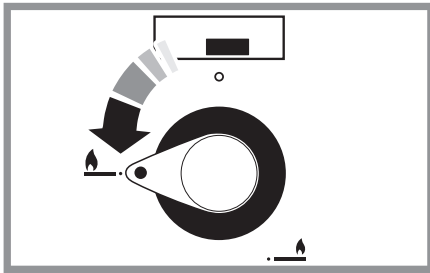

1 The drawing by each knob indicates which burner that knob controls. Push in and turn a knob to the large flame symbol (🔥) and press the igniter button or light with a match.

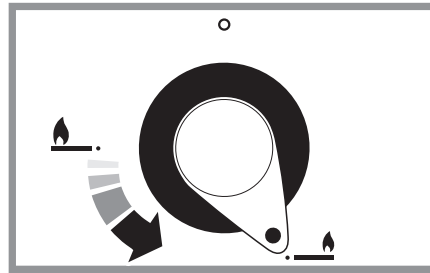

2 Adjust the flame height to suit by turning the knob. On this cooker the low position is beyond high, **not** between high and off. The small flame marks the 'low position'. Turn the knob towards it after the contents of a pan have boiled.

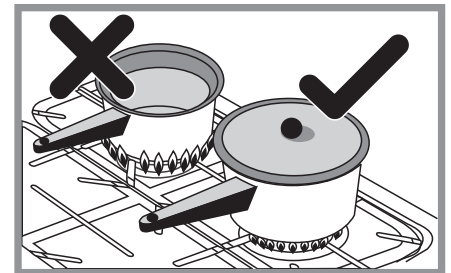

3 Make sure flames are under the pans. Using a lid will help the contents boil more quickly. Pans and kettles with concave bases or down turned base rims should not be used.

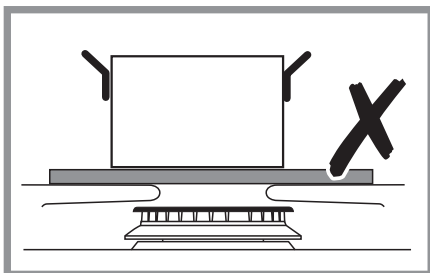

4 Simmering aids, such as asbestos or mesh mats, are NOT recommended. They will reduce burner performance and could damage the pan supports.

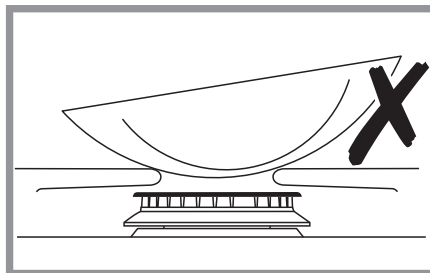

5 Avoid using unstable and misshapen pans that may tilt easily and pans with a very small base diameter e.g. milk pans, single egg poachers. The minimum pan diameter recommended is 120mm (about 4³/₄").

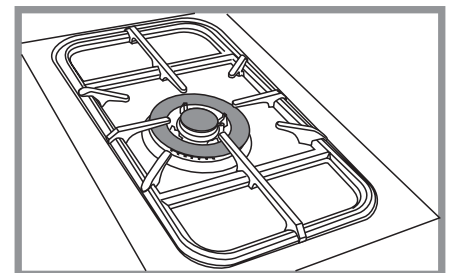

6 The Wok burner is designed to provide even heat over a large area. It is ideal for large pans and stir frying. For heating smaller pans the smaller burners may be more efficient.

2 Minute Tour continues over the page...

2 Minute Tour - continued

THE GRIDDLE

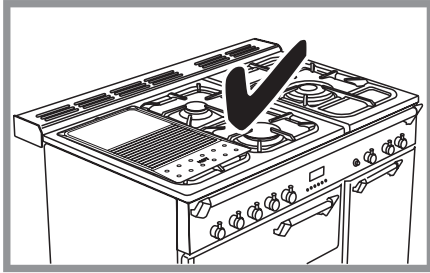

1 The griddle fits a single pan support, front to back. It is designed for cooking food on directly. Don't use pans of any kind on it. The griddle surface is non-stick and metal cooking utensils (e.g. spatulas) will damage the surface. Use heat resistant plastic or wooden utensils.

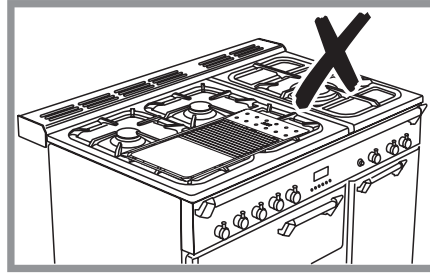

2 Don't put it crossways - it will not fit properly and will be unstable.
Don't put it on the Wok burner - it is not designed to fit the Wok burner pan support.

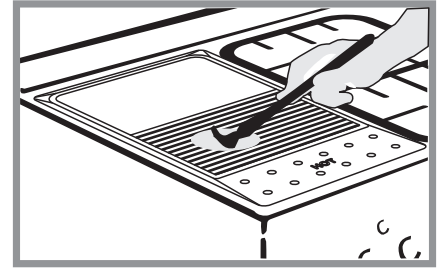

3 Position the griddle over the hotplate burners resting on the pan support. The griddle can be lightly brushed with cooking oil before use. Light the hotplate burners. Adjust the flame heights to suit.

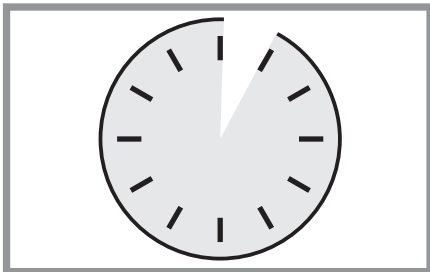

4 Preheat the griddle for a maximum of 5 minutes before adding food. Leaving it longer may cause damage. The controls can be turned to a lower position simply by turning the control knobs towards the lower position marked with the small flame symbol.

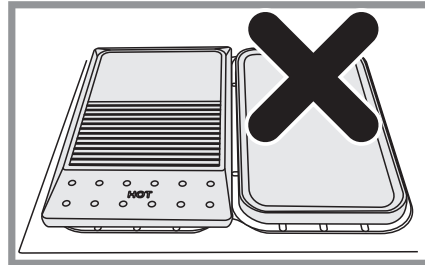

5 Always leave space around the griddle for the gases to escape. **Never** fit two griddles side by side. Large pans should also be spaced well apart. The maximum pan base diameter is 250mm (10in).

The Griddle



Use the following heat settings as a guide for griddle cooking.

High/medium:

Drop scones, Bacon, Chops, Steak, Burgers.

Medium/low:

Potato cakes, Eggs, Fish cakes.

Experience will soon familiarise you with the correct setting to use for cooking. After cooking allow the griddle to cool before cleaning.

Don't put it on the Wok burner - it is not designed to fit the Wok burner pan support.

THE GRILL *More about the grill on page 8*

CAUTION: Accessible parts may be hot when the grill is in use. Young children should be kept away.

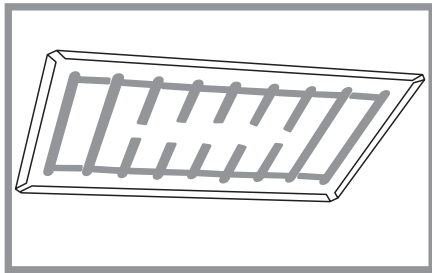

1 The burner does not glow red - food cooks from the heat of the flame. The first time you light the grill there may be a little smoke given off - this is perfectly normal.

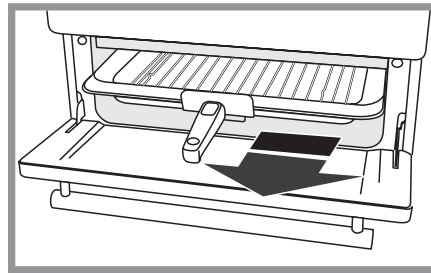

2 Remove the pan from the bottom of the grill compartment.

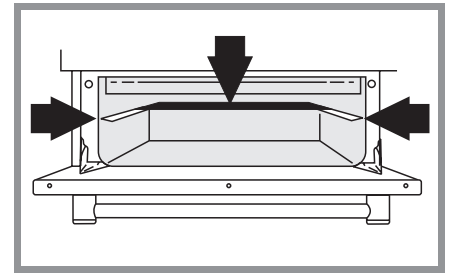

3 After placing your food on the grill tray pan, slide the grill pan onto the side supports just below the burners. Make sure it is pushed right in and touches the back stop.

Natural gas cookers

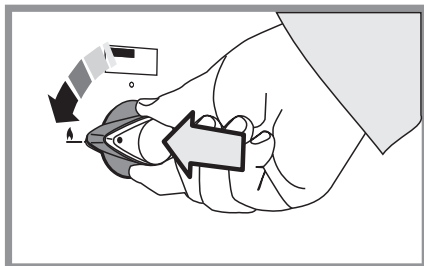

4 Press in the grill knob, turn to the large flame symbol (♠) and press the igniter button or light with a match.

LP gas cookers

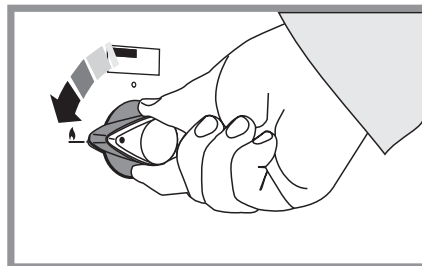

4 The grill has a special safety device with stops the flow of gas to the grill if the flame goes out. Turn the knob to the large flame symbol (♠). Press in the grill knob. This lets gas through to the burner. Keep holding the knob pressed in and press the igniter button or light with a match. Keep holding the button for about 10 seconds

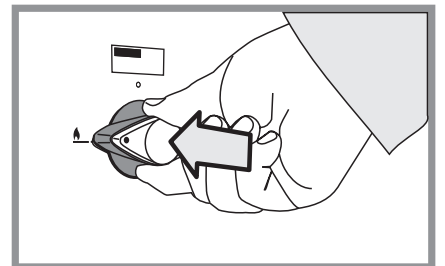

If when you let go of the control knob the burner goes out, the safety device has not held in. Turn off the grill and wait one minute then try again this time holding in the control knob for slightly longer.

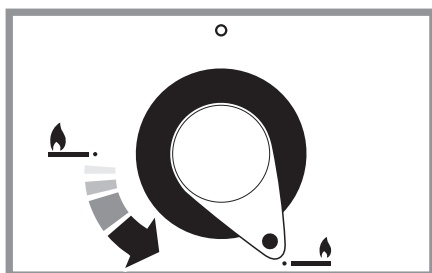

5 The low position, marked with the small flame symbol, is beyond high, not between high and off.

Never close the grill door when the grill is on.

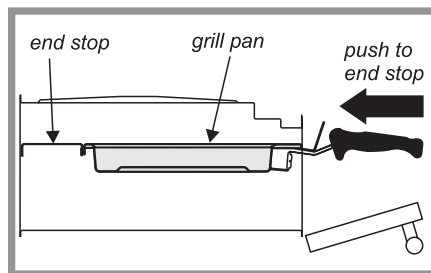

6 For best results preheat for 2 minutes with the grill pan in position. After placing your food on the grill pan grid, slide the grill pan onto the side supports just below the burners. Adjust the flame height to suit by turning the knob.

Make sure it is pushed right in and touches the back stop.

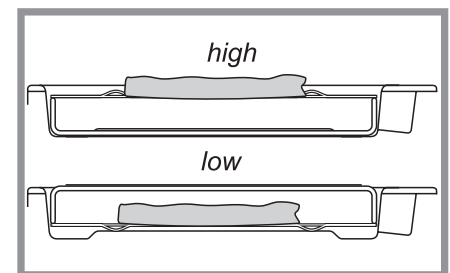

7 The grill pan grid can be turned over to give two grilling positions.

2 Minute Tour continues over the page...

2 Minute Tour - continued

THE MAIN (GAS) OVEN *More about the oven on page 9*

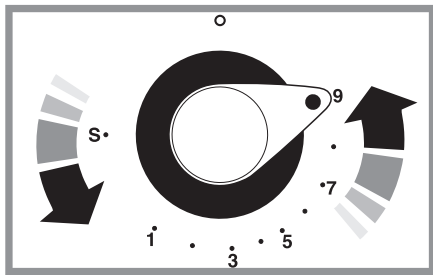

1 Push in and turn the knob controlling the oven to Gas Mark 9. The oven will light automatically.

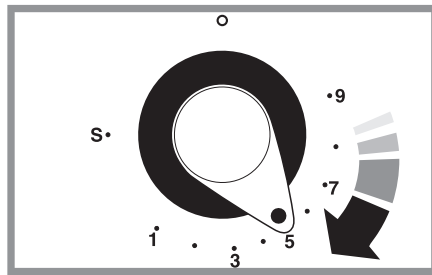

2 Turn the control knob back to the Mark you wish to cook on and for best results pre-heat the oven for 15 minutes before placing your dishes in it.

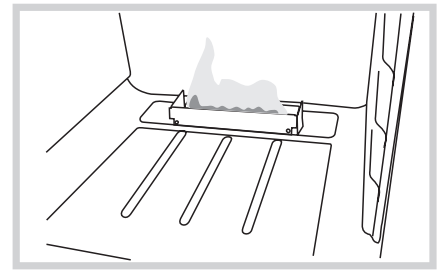

3 The Main oven in your cooker use the our special 'Heatflow' system. Because the oven burner is not hidden under the oven base you will see the burner flames at the back of the oven - this is perfectly normal. Initially the gas will burn with a small flame but after approximately one minute the flame will become larger indicating that the oven is full on.

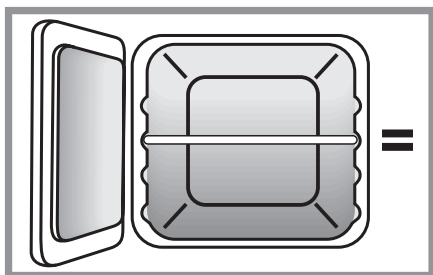

4 Dishes cooking on the central shelf will cook at the gas mark indicated on the knob.

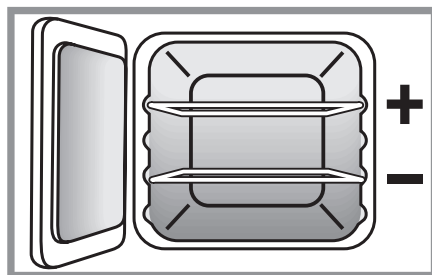

5 Dishes placed above the central position will be cooked at approx. one gas Mark higher, dishes cooked below approx. one gas Mark lower. You can therefore cook dishes requiring different gas Marks at the same time.

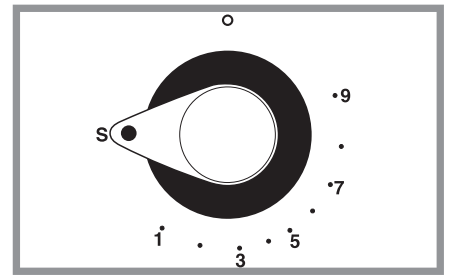

6 *Slow cooking*
More about slow cooking on page 9.
The 'S' setting is a very low temperature for slow cooking, overnight or while you are out or at work. The 'S' setting can also be used for keeping food warm.

Handyrack (Main Oven)

More about the Handyrack on page 9.

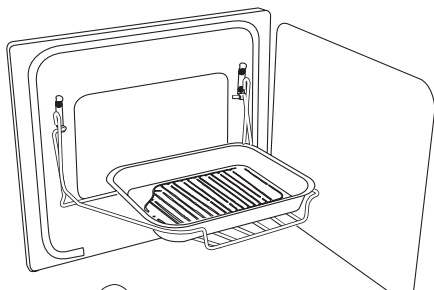

The Handyrack fits to the left hand oven door only. Food cooking on it is easy to attend to, because it's accessible when the door is open. It can be fitted at two different heights. One of the oven shelves must be removed and the other positioned to suit.

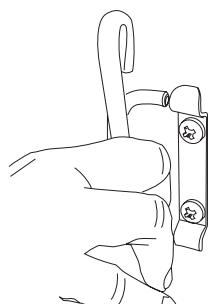

door bracket.

Then spring the other side out to clip it onto the other bracket.

To fit the Handyrack, locate one side of it on the



Oven light

Press the button to turn on the Main oven light.



If the oven light fails, turn off the power supply before you change the bulb. See the 'Troubleshooting' section for details on how to change an oven light bulb.



THE TALL OVEN (ELECTRIC) *More about the tall oven on page 9*

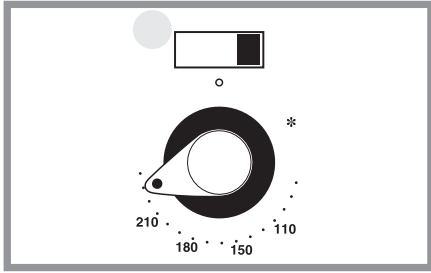

1 Turn the oven knob to the temperature you need.

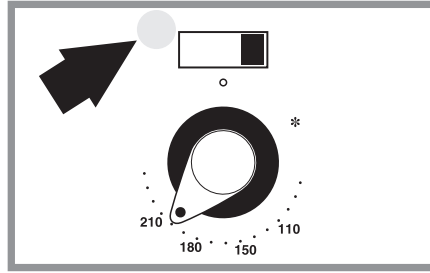

2 The oven indicator light will glow until the oven has reached the temperature you selected. It will then cycle on and off during cooking.

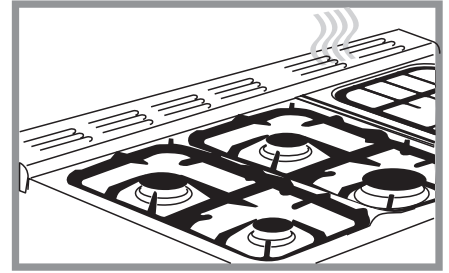

3 When cooking foods with high water content (e.g. oven chips) there may be some steam visible at the grille at the rear of the hotplate. This is perfectly normal.

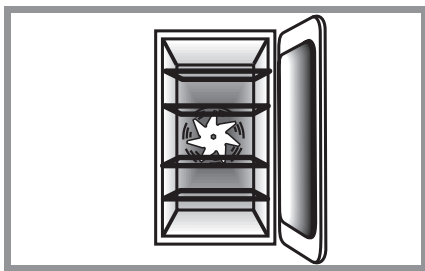

4 The fan in the oven circulates hot air continuously, which means faster more even cooking.

The recommended cooking temperatures for a fanned oven are generally lower than a non-fanned oven.

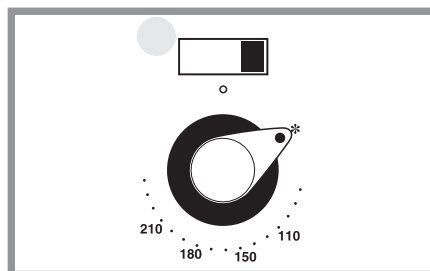

5 * The fan only setting. The fan circulates air inside the oven but the heating element is not turned on. This setting is useful for defrosting small quantities frozen foods.

Whole chickens and large joints of meat should be defrosted in the refrigerator.

THE CLOCK *More about the clock on page 12*



You can use the timer to turn the ovens on and off. Check clock is set to time of day.

To set the time of day

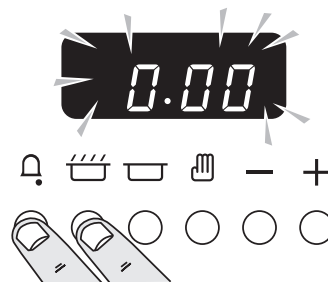

Press and hold as above. At the same time, press (-) or (+) until the correct time shows. Don't forget it's a 24 hour clock. If you make a mistake or press the wrong button, turn off the power supply for a minute or two and start again.

The hotplate burners

You should read 'hotplate burners' in the '2 Minute Tour' before all the following information

If a burner flame goes out, turn the control knob off and leave it for one minute before relighting it.

You can remove the burner parts for cleaning, see page 14.

You should wipe the enamel top surface of the cooker around the hotplate burners as soon as possible after spills occur. Try to wipe them off while the enamel is still warm.

Avoid using unstable and misshapen pans that may tilt easily and pans with a very small base diameter e.g. milk pans, single egg poachers.

The minimum pan diameter recommended is 120mm (about 4³/₄"). Smaller pans will be unstable.

Pans and kettles with down turned base rims should not be used.

The Grill

You should read 'grill' in the 2 Minute Tour' before all the following information

Never close the grill door while the grill is on.

Don't leave the grill on for more than a few moments, without the grill pan underneath it.



For best results, especially on toast, preheat the grill with the grill pan in the cooking position for two minutes before use.

The grill trivet can be removed and the food placed on it while you are waiting for the grill to preheat.

The grill pan grid can be turned over to give two grilling positions.

The Ovens

You should read 'the oven' in the '2 Minute Tour' before all the following information

The wire shelves should always be pushed firmly to the back of the oven.

Baking trays with food cooking on them should be placed level with the front edge of the oven's wire shelves. Other containers should be placed centrally. Keep all trays and containers away from the back of the oven, as overbrowning of the food may occur.

For even browning, the maximum recommended size of a baking tray is 325mm (12³/₄") by 305mm (12") for the main oven and 230mm (9") by 320mm (12¹/₂") for the Tall oven.

When the oven is on, don't leave the door open for longer than necessary, otherwise the knobs may get very hot.



- *Always leave a 'fingers width' between dishes on the same shelf This allows the heat to circulate freely around them.*
- *To reduce fat splashing when you add vegetables to hot fat around a roast, dry them thoroughly or brush lightly with cooking oil.*
- *Where dishes may boil and spill over during cooking, place them on a baking tray.*

The Main (gas) oven

The oven is protected by a safety cut off, which reduces the supply of gas to the oven if the flames go out, e.g. an interruption to the mains supply.

- *Plates can be warmed in the oven on the 'S' setting. The 'S' setting can be used to keep foods hot for 3-4 hours after 'normal' cooking, without drying out or overbrowning.*
- *The Cook & Clean oven liners (see Cleaning your cooker) work better when fat splashes are avoided. Cover meat when cooking.*
- *Sufficient heat rises out of the oven while cooking to warm plates in the grill compartment.*
- *If you want to brown the base of a pastry dish, preheat the baking tray for 15 minutes before placing the dish in the centre of the tray.*

The Tall (electric) oven

Cooking high moisture content foods can create a 'steam burst', when the oven door is opened. When opening the oven stand well back and allow any steam to disperse.

Main Oven shelves

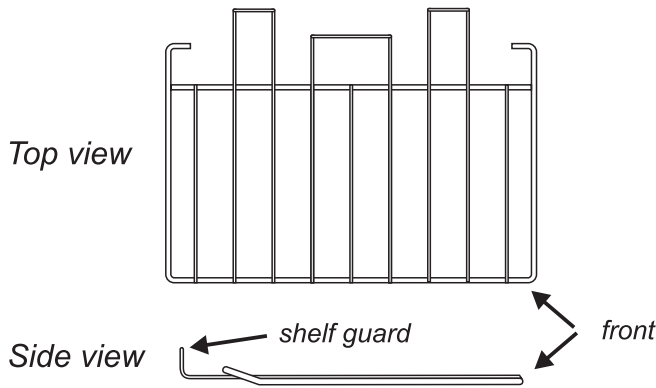

the shelf guard should be at the back pointing upwards
The oven shelves can be easily removed and refitted.

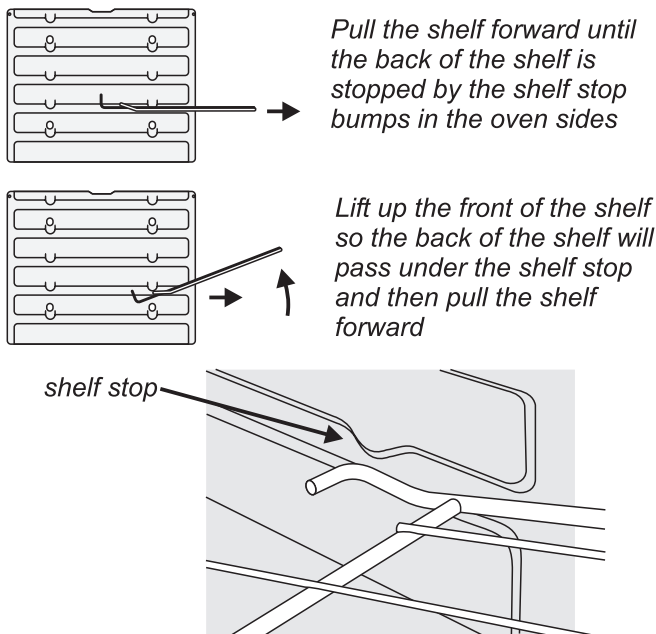

To refit the shelf, line up the shelf with a groove in the oven side and push the shelf back until the ends hit the shelf stop. Lift up the front so the shelf ends clear the shelf stops, and then lower the front so that the shelf is level and push it fully back.

The Handyrack

You should read 'the oven' in the '2 Minute Tour' before all the following information

The maximum weight which can be held by the Handyrack is 5.5kg (12lb).

When the Handyrack is used in its highest position, other dishes can be cooked on the bottom shelf position of the oven or standing on the base of the oven

When the Handyrack is used in its lowest position, other dishes can be cooked on the second shelf position of the oven or standing on the base of the oven.

The roasting tray supplied with the oven fits into the Handyrack.

Tall oven shelves

The tall oven is supplied with four normal cooking shelves

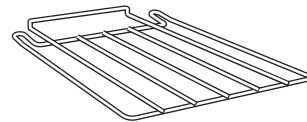

and a plate warming shelf.

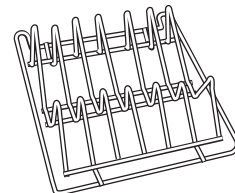

When using the tall oven you can cook on all four shelves at the same time; but make sure they are well spaced out to allow the hot air to circulate.

The oven control settings and cooking times given over the page are intended to be used only as a guide. Individual tastes may require the temperature to be altered to provide a preferred result.

Always leave at least one runner space between shelves when 2 tier cooking. Place baking trays, individual cake tins or baking dishes centrally on the oven shelf. For best results pre-heat the oven for 15mins (Main oven) or until the oven indicator light goes out (Tall oven).

Main Oven cooking guide

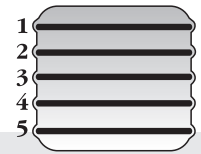

OVEN SHELF POSITIONS

Meat	GAS SHELF POSITION		APPROXIMATE COOKING TIME		
	MARK	FROM TOP			
Beef (no bone)	3	3-4	30-35mins. per 500g.+30-35 mins.	<p><i>Thoroughly thaw frozen joints before cooking. Meat may be roasted at Mk. 7 and the cooking time adjusted accordingly. For stuffed and rolled meats, add approx. 10 min. per 500g. or cook at Mk. 6 or 20min, then Mk. 3 for the remainder.</i></p>	
	6	3-4	20-25mins. per 500g.+20-25 mins.		
Lamb	3	3-4	30-35mins. per 500g.+30-35 mins.		
	6	3-4	25-30mins. per 500g.+25-30 mins.		
Pork and Veal	3	2-3	35-40mins. per 500g.+35-40 mins.		
	6	3-4	25-30mins. per 500g.+25-30 mins.		
Poultry					<p><i>For stuffed poultry, you could cook at Mk. 6 for 20mins. and then Mk.3 for remainder. Don't forget to include the weight of the stuffing. For fresh or frozen prepacked poultry, follow instructions on the pack. Thoroughly thaw frozen poultry before cooking.</i></p>
Chicken (2.3kg)	3	3-4	20-25mins. per 500g.+20-25 mins.		
	6	3-4	15-20mins. per 500g.+15-20 mins.		
Turkey (4.5kg)	3	3-4	25-30mins. per 500g.+25-30 mins.		
	6	3-4	20mins. per 500g.+20 mins.		
(over 4.5kg)	3	4	20mins. per 500g.+20 mins.		
	6	4	15mins. per 500g.+15 mins.		
Duck/ duckling	3	4	25-30mins. per 500g.		
	6	4	20mins. per 500g.		
Casseroles					
	1-2	3-4	2-4 hours according to recipe.		
Yorkshire Pudding					
	7	2	Large tin 30-35 mins. Individual, 10-20 mins.		
Fish					
	5	2	Filletts 15-20 mins. Whole 15-20mins. per 500g.		
	5	2	Steaks according to thickness.		
Cakes				<p><i>When two tier cooking leave at least one runner space between shelves. Position the baking tray with the front edge along the front of the oven shelf.</i></p> <p><i>Rich fruit cakes made with self-raising flour should be cooked on Mk.4 for the first half hour at least and then finished at the setting shown.</i></p>	
Very rich fruit Christmas/ wedding etc.	1	4	45-50mins. per 500g. of mixture.		
Fruit 180mm tin	2	4	2 to 2½ hours.		
Fruit 230mm tin	2	4	Up to 3½ hours.		
Madeira 180mm	3	4	80-90 mins.		
Queen cakes	5	2 & 4 or 3	15-25 mins.		
Scones	7	2 & 4 or 3	10-15 mins.		
Victoria sandwich					
180mm tin	4	2 & 4 or 3	20-30mins.		
230mm tin	4	2 & 4 or 3	30-40 mins.		
Desserts				<p><i>If cooking more than one tart at the same time, swap them over at approx. 25 mins. For even browning the maximum size of baking tray recommended is 320mm x 305mm. This ensures free heat circulation.</i></p> <p><i>If cooking a two tier load, when the top tray is removed, the tray in the lower position should be raised to the higher shelf, or the trays interchanged, for the remaining cooking time.</i></p>	
Shortcrust tarts	6	2 & 4	40-60 mins. on pre-heated tray.		
Fruit pies	6	2-3	35-45 mins.		
Tartlets	6	2-3	10-20 mins. according to size.		
Flaky/rough puff	7	2-3-4	20-40 mins. according to size.		
Puff pastry	8	2-3-4	20-40 mins. according to size.		
Meringues	'S'	3	1½ to 2 hrs.		
Baked egg custard	3	3	45-60 mins.		
Baked sponge pudding	5	3	40-45 mins.		
Milk pudding	1-2	3	2-3 hrs.		

Tall Oven cooking guide

Food	Oven Temperature	Approximate Cooking Time
Fish		
	180°C	Filletts 15-20mins.
	180°C	Whole 10mins.per 500g + 10mins.
	180°C	Steaks according to thickness.
ROAST MEATS		
Beef with bone	150°C	20-25mins. per 500g + 20-25mins.
	190°C	15-20mins. per 500g + 15-20mins.
Beef without bone	150°C	30-35mins. per 500g + 30-35mins.
	190°C	20-25mins. per 500g + 20-25mins.
Lamb	170°C	30-35mins. per 500g + 30-35mins.
	190°C	25-35mins. per 500g + 25-30mins.
Pork	150°C	35-40mins. per 500g + 35-40mins.
	190°C	25-30mins. per 500g + 25-30mins.
Stuffed and rolled - Add approx. 10 mins. per 500g to above cooking times or cook at 200°C for 20mins. then 160°C for remainder.		
<i>Thoroughly thaw frozen joints and poultry before cooking.</i>		
POULTRY		
Chicken	150°C	20-25mins. per 500g + 20-25mins.
	190°C	15-20mins. per 500g + 15-20mins.
Turkey	150°C	20-25mins. per 500g + 20-25mins.
	200°C	15-20mins. per 500g + 15-20mins.
Stuffed Poultry - Cook at 200°C or at 200°C for 20mins. then 160°C for remainder. Prepacked (fresh or frozen) follow packers cooking times		
THOROUGHLY THAW FROZEN POULTRY BEFORE COOKING		
CASSEROLE	140°C	2-4hrs according to recipe.
YORKSHIRE PUDDING	200°C	Large tin 30-35mins. Individual 10-20mins.
CAKES		
Very Rich Fruit	140°C	45-50mins. per 500g mixture
Rich fruit (180mm)	145°C	2½-3hrs.
Madeira (180mm)	150°C	80-90mins.
Queen Cakes	170°C	15-25mins.
Scones	200°C	10-15mins.
Victoria Sandwich	170°C	20-30mins.
PASTRIES		
Plate Tart	190°C	45-50mins. Interchange after 25mins.
Fruit Pie	190°C	35-40mins.
Tartlets	190°C	15-20mins. according to size.
Puff Pastry	200°C	20-40mins. according to size.
BREAD	200°C	20-30mins.
MERINGUES	100°C	2-2½hrs
PUDDINGS		
Baked Egg Custard	150°C	45mins.-1hr.
Baked sponge pudding	180°C	40-45mins.
Milk pudding	150°C	2-3hrs.

500g is approximately 1lb (1lb 2oz)

'S' (Slow) cooking (Main oven)

The 'S' setting is a low temperature setting.

You can cook on 'S' throughout, or use a 30 minute 'boost' period at gas mark 6 and then 'S' cook.

When roasting joints, poultry or pot roasting, always cook at Mark 6 for 30 minutes at the beginning of the cooking period.

You can 'S' cook for periods of 6 to 12 hours. This technique is particularly useful if you want to cook a dish overnight or while you are out at work during the day.

Frozen foods must be thoroughly thawed out before 'S' cooking.

Whole poultry should not be cooked on 'S'. Chicken casseroles are fine.

Casseroles must be brought to boiling point on the hotplate immediately before 'S' cooking.

Poultry and rolled joints should not be stuffed before cooking. The stuffing should be cooked separately. Poultry and pork should be cooked in the top half of the oven, and other meats not lower than shelf position 4.

A roasting joint should be covered with cooking foil, or with a roasting bag to reduce shrinkage and retain juices.

Should further browning be necessary, uncover the meat and increase the temperature to Mark 4 for a short period.

Cut root vegetables into small pieces unless cooking whole, e.g. jacket potatoes.

Cover dishes tightly with a lid or foil to prevent evaporation and transfer of flavour.

Once the oven has been loaded and the 'S' setting is in operation resist the temptation to open the oven door. Heat will be lost and the cooking time extended.

A meat thermometer is recommended for checking that a joint or poultry is sufficiently cooked. Insert the probe through the thickest part of the meat. The temperatures to be expected are as follows.-

Beef	rare	60°C/ 140°F
	medium	71°C/ 160°F
	well done	77°C/ 170°F
Lamb		82°C/ 180°F
Pork	fresh	88°C/ 190°F
	cured	77°C/ 170°F
Poultry		90°C/ 195°F
Veal		77°C/ 170°F

Cooking using the timer

The timer can be used to turn just one oven or both on and off automatically. The start and stop time must be the same for both ovens but different cooking temperatures can be set.

If you want to turn one of the ovens on at the same time as the timer is set for automatic cooking, you must wait until the timer has turned on the oven/ ovens first. Then you can adjust either of them manually in the normal way.

You can set the oven to turn on any time over the following 24 hour period.

If you want to cook more than one dish, choose dishes which require approximately the same time. However, dishes can be 'slowed down' slightly by using small containers and covering them with aluminium foil, or 'speeded up' slightly by cooking smaller quantities or placing in larger containers.

Very perishable foods such as pork or fish should be avoided if a long delay period is planned, especially in hot weather.

*Don't place warm food in the oven.
Don't use an oven already warm.
Don't use if an adjoining oven is warm.*

Avoid using wine or beer if there is a delay period, as fermentation may take place.

To avoid curdling, cream should be added to dishes just before serving.

Fresh vegetables which may discolour during a delay period should be coated in melted fat or immersed in a water and lemon juice solution.

Fruit pies, custard tarts or similar wet mixtures on top of uncooked pastry are only satisfactory if there is a short delay period. Dishes containing leftover cooked meat or poultry should not be cooked automatically if there is a delay period.

Whole poultry must be thoroughly defrosted before placing in the oven. Check that meat and poultry are fully cooked before serving.

The clock

To set the correct time of day.

See the '2 Minute Tour' at the beginning of this guide.

To time something that's cooking (minute minder)

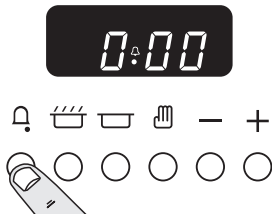

Press and hold as above. At the same time press (-) or (+) until the time you want to cook for is shown, as below.

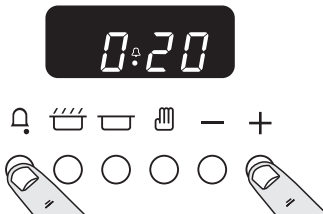

You can check time remaining by pressing and cancel the beeper by pressing .

To stop automatically

Use when you have started the oven manually.

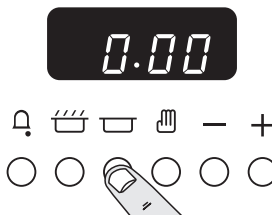

Press and hold as above. At the same time press (-) or (+) until your required 'Stop Time' shows. AUTO will show in the display. When your cooking is finished the beeper sounds. **TURN THE OVEN KNOB TO 0 FIRST**, then press once to stop the beep, press again to return to manual cooking.

To start and stop the oven automatically

Before you set the clock, you must have two numbers clearly in mind.

The 'cook period', which is the period of time you want the oven to cook.

The 'stop time', which is the time of day you want the oven to stop cooking.

You cannot set a start time directly - this is set automatically by setting the cooking period and stop time.

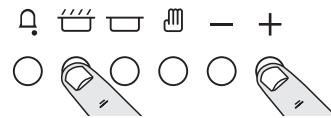

Press and hold as above. At the same time press (-) or (+) until your required 'cook period' shows.



Then press and hold as above. At the same time press (-) or (+) until your required 'stop time' shows.

AUTO will show in the display.

Set the oven to the required temperature. When your cooking is finished the beeper sounds. **TURN THE OVEN KNOB TO 0 FIRST**, then press once to stop the beep, press again to return to manual cooking.

If you are out, don't worry about the beeper going off, it stops after a while. When you return, **TURN THE OVEN KNOB TO 0 FIRST**, then press twice, to return to manual cooking.

AUTO is showing, you want to reset to manual cooking.

When cancelling an automatic setting, any cooking time already set must be returned to 0.00 before you can return to manual, by pressing the button.

Cleaning your cooker

Essential information

Before thorough cleaning isolate the electricity supply. Remember to switch on the electricity supply before use.

Never use paint solvents, washing soda, caustic cleaners, biological powders, bleach, chlorine based bleach cleaners, coarse abrasives or salt. Don't mix different cleaning products - they may react together with hazardous results.

Recommended cleaning materials are shown in the chart below.

If you want to move your cooker for cleaning, see the section called 'Moving your cooker'.

All parts of the cooker can be cleaned with hot soapy water - **but take care that no surplus**

	Cream Cleaner	Nylon Scourer	Aerosols (*VEA)	Diswasher
GRILL				
Grill pan	✓	✓	✓	✓
Grill pan grid	✓	✓		✓
Grill chamber	✓	✓		
HOTPLATE				
Pan supports	✓	✓	✓	✓
Enamel burner caps	✓	✓	✓	✓
Burner trim rings	✓			
Burner head	✓	✓		
Hotplate top	✓	✓		
OVEN				
Inside oven ‡	✓	✓	✓	
Door surround	✓	✓	✓	
Oven shelves	✓	✓		✓
Handyrack	✓	✓		✓

‡ Indicates how to clean after the oven linings have been removed. See opposite page for how to remove the oven linings

* VEA is the Vitreous Enamel Association. Look for aerosols with the VEA label.

Hotplate burners

Some models have a separate trim ring, which fits on the burner head.

The burner heads and caps can be removed for cleaning. Make sure they are absolutely dry before replacing.

The LH hotplate

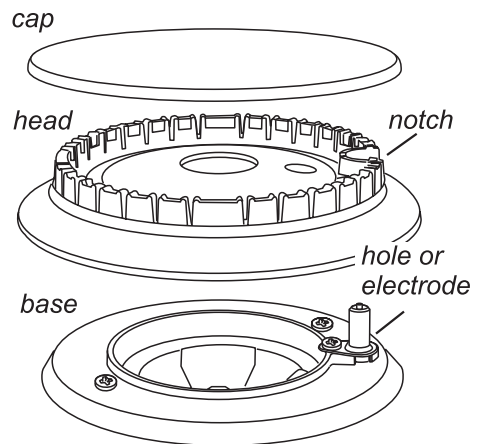

When refitting the burner head, make sure that the notch lines up with the electrode or hole in the base. Check that the burner head is level and that the cap is fitted centrally on the burner head.

The Wok burner

The Wok burner is a little more complicated but it also can be taken apart for cleaning.

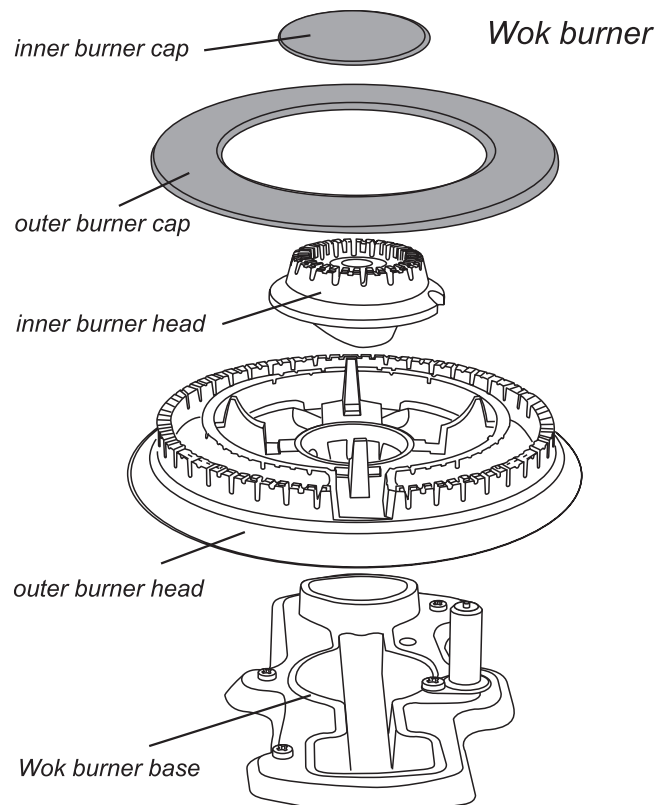

When reassembling the Wok burner, turn over the large base ring and find the 'D' shaped area.

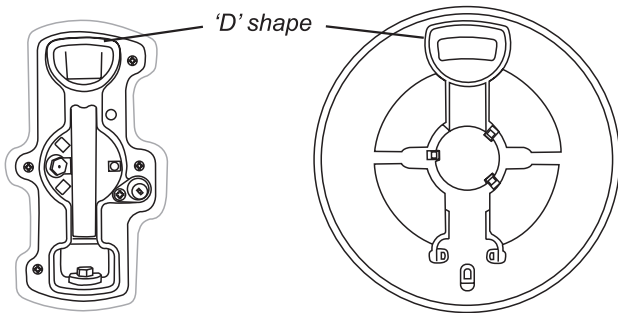

burner base

underside of burner head

Turn the head until the 'D' matches the one on the burner base. Turn the head over and place it on the burner base. To fit the small inner burner, find the larger electrode notch in the burner rim. Line this up with the white ignition electrode and place the inner burner on the large base ring.

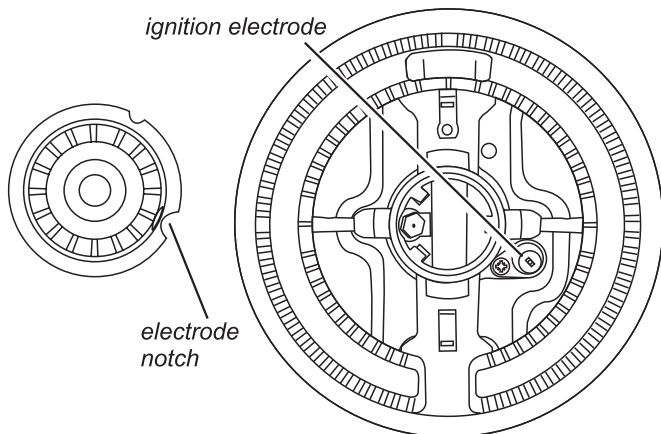

ignition electrode

electrode notch

Now fit the two trim rings, making sure that they are sitting down properly.

Grill

The face of the grill burner will darken with use - this is perfectly normal. Any fat or grease will burn off. Do not try to clean it - the small holes could get blocked and affect burner performance.

The grill pan and grid should be washed in hot soapy water. Stubborn particles may be removed from the grid by using a nylon brush.

Control Panel and Doors

Avoid using any abrasive cleaners including cream cleaners, e.g. Cif, on brushed Stainless Steel surfaces. For best results use a liquid detergent e.g. Domestos Multi Surface Cleaner.

The control panel and control knobs should only be cleaned with a soft cloth wrung out in clean hot soapy water - **but take care that no surplus water seeps into the appliance.** Wipe with a clean dampened cloth then polish with a dry

cloth. The oven doors should only be cleaned with a soft cloth wrung out in clean hot soapy water.

Cookers with window doors

On some models the oven door front panel can be taken off so that the glass panels can be cleaned. If the top edge of the oven door of your cooker has a line of holes and there are screws in the side edges then it can be taken apart for cleaning.

Move the cooker forward to gain access to the sides (see the 'Moving the cooker' section of these instructions).

Open the oven door slightly and remove the front panel fixing screws from the door sides (two each side).

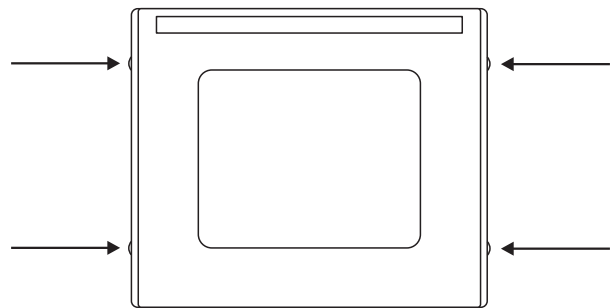

some window doors only

Carefully lift off the outer door panel. The inside face of the glass panels can now be cleaned - take care not to disturb or wet the door insulation. Please note that the door is triple glazed but the inner two panels are fixed and should not be separated. After cleaning carefully refit the outer door panel and replace the side fixing screws.

The Main Oven

Cleaning is easier if carried out while the oven is still warm. Before cleaning, cover the burner to prevent the burner holes becoming blocked.

The inside of the oven and inner door panel can be cleaned using any cleaner bearing the Vitreous Enamel Association (VEA) label.

Take care not to disturb the oven thermostat temperature sensor at the top of the oven opening.

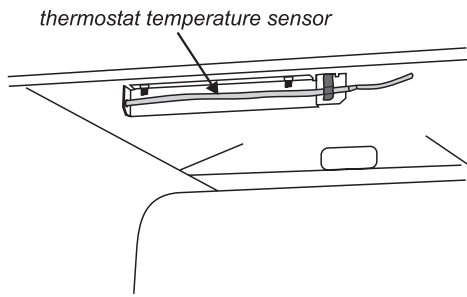

The enamelled oven burner trim (supplied with some models only) can be removed for cleaning.



The oven burner trim hooks onto the front of the oven burner bracket.

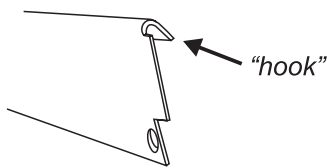

When refitting make sure that the trim is in the middle of the front of the oven burner bracket.

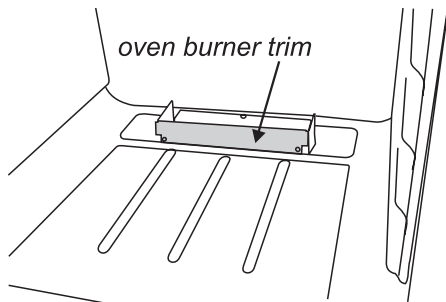

The Main Oven side linings

The oven has removable oven side lining panels that have been coated with special enamel that partly cleans itself. This does not stop all marks on the lining, but helps to reduce the amount of manual cleaning needed.

The self cleaning panels work better above gas Mark 6. If you do most of your cooking below this temperature, occasionally remove the panels and wipe with a lint free cloth and hot soapy water. The panels should then be dried and replaced and the oven heated at Gas Mark 7 for about one hour. This will ensure the self cleaning panels are working effectively.

Don't use steel wool (Brillo) or any other materials that will scratch the surface. Don't use oven cleaning pads.

Before cleaning the oven, cover the burner at the rear to stop the holes getting blocked as you clean. If they are accidentally blocked, clean them out with thin wire, such as fuse wire.

Removing the Oven Linings

The lining panels can be removed for cleaning and for cleaning behind. Remove the shelves first.

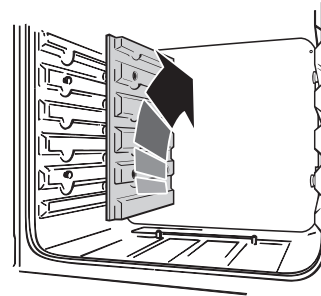

Each side of the oven is fixed with four fixing screws. You don't have to remove the screws to remove the oven linings. Lift each side panel upwards and they will slide off the screws. Then pull them forwards.

Once the linings are removed, the oven enamel interior can be cleaned.

The Tall Oven

To clean the oven sides slide out the shelves, unhook the supports from the oven sides and lift out.

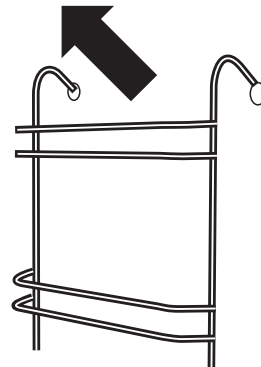

Moving your cooker

Switch off the electricity supply.

The cooker is heavy, two people may be required to move it. There are two levelling rollers at the back and also two screw down levelling feet at the front.

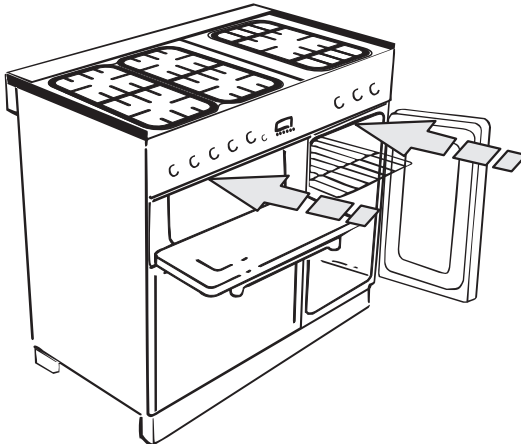

Open the grill door and right hand oven door so that you can get a good grip on the bottom of the fascia panel as you move the oven. Lift the front of the cooker slightly and pull forward.

Do not move the oven by pulling the door handles or knobs.

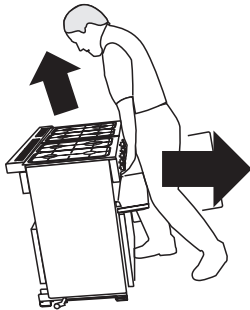

Move the oven a bit at a time, checking behind it to make sure the gas hose is not caught. Make sure both electricity and gas cables have sufficient slack to move the cooker forward as you go along.

If a stability chain is fitted, release it as you ease the cooker out. Don't forget to refit it when you replace the cooker.

When you replace the cooker, again check behind to make sure that the electricity and gas cables are not caught or trapped.

Troubleshooting

Food is cooking too slowly, too quickly, or burning

Cooking times may differ from your previous oven. The oven control settings and cooking times are intended to be used only as a guide. Individual tastes may require the gas mark to be altered one gas Mark either way, to get the results you want. Try cooking at a higher shelf position and/or higher Mark. Oven cooking times and temperatures may need to be increased when other burners are in use. Are the Main oven burner ports blocked with spilt food?

The oven is not cooking evenly

Do not use a tin or baking tray larger than 340mm x 305mm in the main oven or 232mm x 321mm in the Tall oven.

If you are cooking a large item, be prepared to turn it round during cooking.

If more than one shelf is used, check that space has been left for the heat to circulate. When a baking tray is put into the oven, make sure the front edge is level with the front of the shelf.

Check that the door seal is not damaged and that the door catch adjusted so that the door is held firmly against the seal.

NB the seal is intended to have a gap at the bottom of the door

A dish of water when placed on the shelf should be the same depth all over.

(For example, if it is deeper at the back, then the back of the cooker should be raised up or the front lowered). If the cooker is not level arrange for your supplier to level it for you.

Oven not coming on when turned on manually

Problems with the burner (main oven)

Are the oven burner ports blocked with spilt food? Are the burner flames starting low and then rising to full height?

Electrical Problems

Is the power on? Is the clock illuminated? If not there may be something wrong with the power supply. Is the clock flashing 0.00? If so set it to the correct time of day. Has the Timer been set to AUTO by mistake? If AUTO is showing on the clock display, press the 'cook period' button and reduce any set cooking time showing to 0.00, with the (+) and (-) buttons. Press the  button twice.

If this does not solve the problem contact a service person.

Oven not coming on when automatic cooking

Timer set correctly but oven knob left OFF by mistake?

Oven temperature getting hotter as the cooker gets older

If turning the knob down has not worked or only worked for a short time then you may need a new thermostat. This should be fitted by a service person.

Steam is coming from the Tall oven

When cooking foods with a high water content (e.g. oven chips) there may be some steam visible at the rear grille. Take care when opening the oven door as there may be a momentary puff of steam when the oven door is opened. Stand well back and allow any steam to disperse.

The Tall oven fan is noisy

The note of the oven fan may change as the oven heats up - this is perfectly normal.

Troubleshooting

Grill Ignition faulty

Is the power on? Is the clock illuminated? If not there maybe something wrong with the power supply. See 'power supply' section further on.

Grill not cooking properly

Are you using the pan and trivet supplied with the cooker? Is the pan being used on the runners, not the floor of the compartment? Is the grill tray pushed fully back to stop?

Hotplate ignition or hotplate burners faulty

Is the power on? Is the clock illuminated? If not there maybe something wrong with the power supply.

See 'power supply' section further on.

Are the sparker (ignition electrode) or burner slots blocked by debris?

Is the burner trim correctly located?

Are the burner caps correctly located?

See the section entitled 'Cleaning'

Hotplate burners will not light

If only one or all the hotplate burners will not light, make sure that the parts have been replaced correctly after wiping or removing for cleaning.

Check that there is not a problem with your gas supply. You can do this by making sure that other gas appliances you may have are working.

Do the burners spark when you push the button? If not check the power is on - is the clock illuminated?

The Main oven light is not working

The bulb has probably blown. You can buy a replacement bulb (which is not covered under the guarantee) from a good electrical shop. Ask for an Edison screw fitting 15w 240v lamp, FOR OVENS. It must be a special bulb, heat resistant to 300 °C. See the HELP leaflet for spares by mail order.

There is a glass cover over the bulb which has to be removed before you can replace the bulb.

Turn off the power supply.

Unscrew the bulb cover by turning anticlockwise and unscrew the bulb. Screw in the new bulb and refit the bulb cover.

Power supply. You think there may be a problem with it

First check the socket by trying out another piece of electrical equipment in it. If that works, replace the fuse in the cooker plug. Use a 13 amp fuse.

Power failure

In the event of a failure in the electrical supply the grill and hotplate may be lit using a match. The ovens however cannot be used either manually or automatically until power is restored.

Oven ignition faulty (Main gas oven)

Is the power on? Is the clock running? - if not there may be something wrong with the power supply.

See the section on 'Checking the power supply'.

Check that the electrode and burner slots are not blocked by debris.

Has the Timer been set to auto by mistake, or after power cut?

Has the Timer been set correctly but oven tap not left OFF by mistake?

General Safety Instructions



The cooker must be installed by a CORGI registered engineer in accordance with the installation instructions. The installation must comply with the relevant regulations and also the local gas and electricity supply companies requirements.

IF YOU SMELL GAS

Don't turn electric switches on or off.

Don't smoke

Don't use naked flames

Do turn off the gas at the meter or cylinder

Do open doors and windows to get rid of the gas

Call your gas supplier.

If you are using natural gas in the UK ring British Gas - Trans Co on

0800 111 999

This appliance is designed for domestic cooking only. Use for any other purpose could invalidate any warranty or liability claim.

The use of a gas cooking appliance results in the production of heat and moisture in the room in which it is installed. Ensure that the kitchen is well ventilated: keep natural ventilation holes open or install a mechanical ventilation device, (mechanical extractor hood).

Prolonged intensive use of the appliance may call for additional ventilation, for example opening a window, or more effective ventilation, for example increasing the level of mechanical ventilation where present.

The cooker should be serviced by a qualified service engineer and only approved spare parts used. Have the installer show you the location of the cooker control switch. Mark it for easy reference. Always allow the cooker to cool and then switch off at the mains and before cleaning or carrying out any maintenance work, unless specified otherwise in this guide.

All parts of the cooker become hot with use and will retain heat even after you have stopped cooking.

Take care when touching cooker, to minimize the possibility of burns, always be certain that the controls are in the OFF position and that it is cool before attempting to clean the cooker.

Use dry oven gloves when applicable - using damp gloves might result in steam burns when you touch a hot surface. Never operate the cooker with wet hands.

Do not use a towel or other bulky cloth in place of a glove. They might catch fire if they touch a hot surface.

Clean with caution. If a wet sponge or cloth is used to wipe spills on a hot surface, be careful to avoid steam burns. Some cleansers can produce noxious fumes if applied to a hot surface.

Do not use unstable saucepans and position the handles away from the edge of the hotplate.

Babies, toddlers and young children should not be allowed near the cooker at any time. They should never be allowed to sit or stand on any part of the appliance. Teach them not to play with controls or any other part of the cooker.

Never store anything of interest to children in cabinets above a cooker - children climbing on the cooker to reach them could be seriously injured.

Clean only parts listed in this guide.

In the interests of hygiene and safety the cooker should be kept clean at all times as a build up in fats and other food stuff could result in a fire.

Always keep combustible wall coverings or curtains etc. a safe distance away from your cooker.

Do not spray aerosols in the vicinity of the cooker while it is in on.

Do not store or use combustible materials, or flammable liquids in the vicinity of this appliance.

Do not use water on grease fires. Never pick up a flaming pan. Turn the controls off. Smother a flaming pan on a surface unit by covering the pan completely with a well fitting lid or baking tray. If available use a multipurpose dry chemical or foam-type fire extinguisher.

Never leave the hotplate unattended at high heat settings. Pans boiling over can cause smoking and greasy spills may catch on fire.

Never wear loose-fitting or hanging clothes while using the appliance. Be careful when reaching for items stored in cabinets over the hotplate. Flammable material could be ignited if brought in contact with a hot surface unit and may cause severe burns.

Take great care when heating fats and oils, as they will ignite if they get too hot.

Use a deep fat thermometer whenever possible to prevent overheating fat beyond the smoking point.

Never leave a chip pan unattended. Always heat fat slowly, and watch as it heats. Deep fry pans should be only one third full of fat. Filling the pan too full of fat can cause spill over when food is added. If you use a combination of oils or fats in frying, stir them together before heating, or as the fats melt.

Foods for frying should be as dry as possible. Frost on frozen foods or moisture on fresh foods can cause hot fat to bubble up and over the sides of the pan. Carefully watch for spills or overheating of foods when frying at high or medium high temperatures. Never try to move a pan of hot fat, especially a deep fat fryer. Wait until the fat is cool.

When the grill is on, do not use the top of the flue (the slot along the back of the cooker) for warming plates, dishes, drying tea towels or softening butter.

When using an electrical appliance near the hotplate, be sure that the cord of the appliance does not come into contact with the hotplate.

If you find a crack in the Warmer surface immediately disconnect the appliance from the supply and arrange for its repair.

Take care that no water seeps into the appliance

Only certain types of glass, glass-ceramic, earthenware or other glazed containers are suitable for hotplate cooking; others may break because of the sudden change in temperature.

Do not allow anyone to climb, stand or hang on any part of the cooker.

Do not use aluminium foil to cover shelves, linings or the oven roof.

Make sure that your kitchen is well ventilated at all times. Use extractor fans or hoods when fitted.

Never heat unopened food containers. Pressure build up may make container burst and cause injury.

The cooker is designed for cooking foods only and must not be used for any other purpose.

The oven should NOT be used for heating the kitchen, not only does this waste fuel but the control knobs may become overheated.

When the oven is on DO NOT leave the oven door open for longer than necessary.

The specification of this cooker should not be altered.

This appliance is heavy, take care when moving it.

When the cooker is not in use ensure that the control knobs are in the off position.

Dear Installer

Before you start your installation, please complete the details BELOW.

If your customer has a problem relating to your installation they will be able to contact you easily.

Thank you

Installer's Name

Installer's Company

Installer's Telephone number

You must be aware of the following safety requirements & regulations

Prior to installation, ensure that the local distribution conditions (nature of the gas and gas pressure) and the adjustment of the appliance are compatible.

This appliance shall be installed in accordance with the regulations in force and only in a well ventilated space. Read the instructions before installing or using this appliance.

In the UK the regulations and standards are as follows:-

In your own interest and that of safety, it is law that all gas appliances be installed by competent persons. CORGI registered installers undertake to work to safe and satisfactory standards. Failure to install the appliance correctly could invalidate any warranty or liability claims and lead to prosecution. The cooker must be installed in accordance with

- ▶ All relevant British Standards / Codes of Practice, in particular BS 5440 Part 2 2000,
- ▶ For Natural Gas - BS 6172 : 1990 and BS 6891 : 1998
- ▶ For LP Gas - BS 5482-1:1994 (when the installation is in a permanent dwelling), BS 5482-2:1977, (when the installation is in a caravan or other non permanent dwelling), or BS 5482-3:1999 , (when the installation is in a boat).
- ▶ The Gas Safety (Installation and Use) regulations 1998.
- ▶ The relevant Building / IEE regulations.

Provision of Ventilation

This appliance is not connected to a combustion products evacuation device. Particular attention shall be given to the relevant requirements regarding ventilation.

The room containing the cooker should have an air supply in accordance with BS 5440 Part 2 : 2000. All rooms require an openable window or equivalent, while some rooms require a permanent vent in addition to the openable window. The cooker should not be installed in a bedsitting room with volume less than 20m³. If it is installed in a room of volume less than 5m³ an air vent of effective area 100cm² is required; if it is installed in a room of volume between 5m³ and 10m³, an air vent of effective area 50cm² is required; while if the volume exceeds 11m³, no air vent is required.

If there are other fuel burning appliances in the same room, BS 5440 Part 2 : 2000 should be consulted to determine the requisite air vent requirements.

Location of Cooker

The cooker may be installed in a kitchen/kitchen diner but NOT in a room containing a bath or shower.

NOTE:

An appliance for use on LPG shall not be installed in a room or internal space below ground level. e.g. in a basement.

This appliance is designed for domestic cooking only. Use for any other purpose could invalidate any warranty or liability claim.

You will need the following equipment to complete the cooker installation satisfactorily

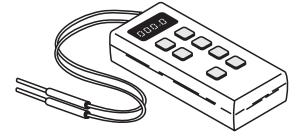
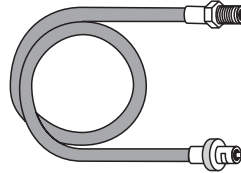
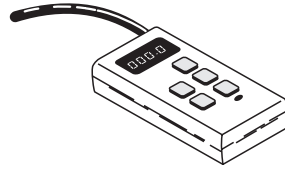
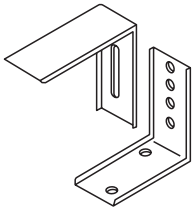

STABILITY BRACKET

If the cooker is to be supplied with gas through a flexible hose, a stability bracket or chain must be fitted.

These are not supplied by with the cooker but are available at most builders merchants.

GAS PRESSURE TESTER

FLEXIBLE GAS HOSE

Must be in accordance with the relevant standards. For LP Gas it should be suitable for LPG, capable of 50mbar pressure, 70°C temperature rise and carry a red stripe, band or label

MULTIMETER (for electrical checks)

You will also need the following tools:

1. Electric drill
2. Masonry drill bit
(only required if fitting the cooker on a stone or concrete floor)
3. Rawlplugs
(only required if fitting the cooker on a stone or concrete floor)
4. Steel tape measure
5. Cross head screwdriver
6. Flat head screwdriver
7. 4mm & 3mm Allen keys
8. Spirit level
9. Pencil
10. Adjustable spanner
11. Screws for fitting stability bracket

Positioning the Cooker

The diagrams below show the minimum recommended distance from the cooker to nearby surfaces.

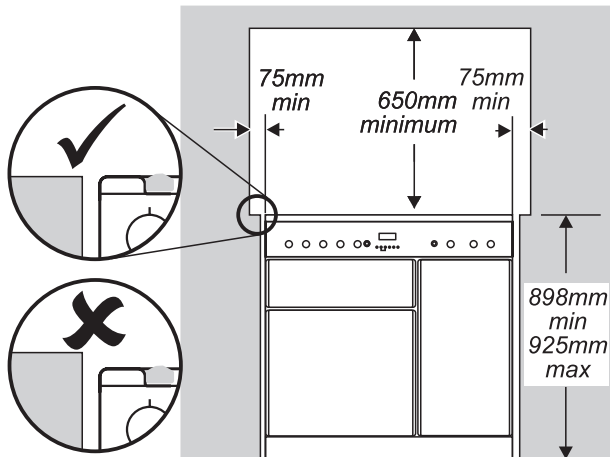

The hotplate surround should be level with, or above, any adjacent work surface. Above hotplate level a gap of 75mm should be left between each side of the cooker and any adjacent vertical surface.

For non-combustible surfaces (such as unpainted metal or ceramic tiles) this can be reduced to 25mm.

A minimum space of 650mm is required between the top of the hotplate and a horizontal combustible surface.

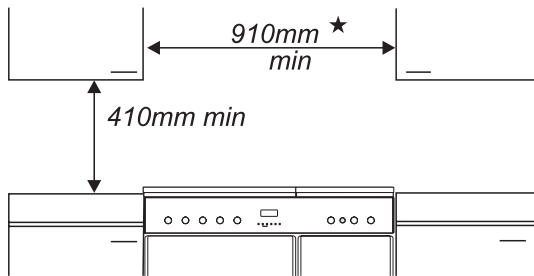

*Any cooker hood should be installed in accordance with the hood manufacturer's instructions.

For safety reasons curtains must not be fitted immediately behind the cooker.

We recommend a gap of 910mm between units to allow for moving the cooker. If a flush fit is required, fit the cooker up to the unit at one side then fit the unit the other side.

A clearance of 130mm is required if the cooker is near a corner of the kitchen to allow the oven doors to open.

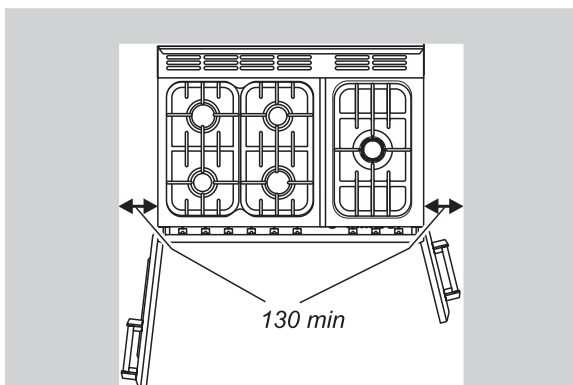

Checking the parts

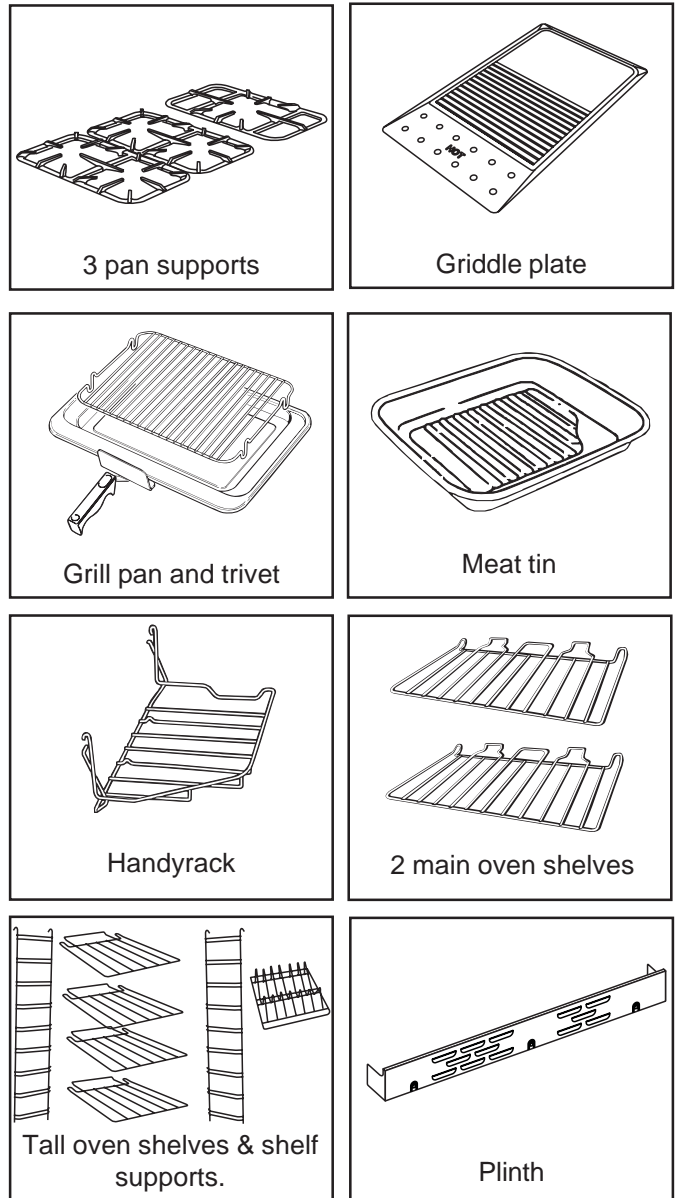

Unpacking the Cooker

Do not take any packaging off the cooker until it is directly in front of the place it is to be installed (unless it will not fit through a door in its outer packaging). Cut the banding straps and lift the cardboard box off the cooker, **LEAVING THE COOKER STANDING ON THE BASE PACKAGING.** See the loose unpacking sheet.

Moving the Cooker

The cooker is very heavy. Take great care. We recommend two people manoeuvre the cooker. Ensure that the floor covering is firmly fixed, or removed to prevent it being disturbed when moving the cooker around. You will need the levelling tool.

From the back tilt the cooker forward and remove the rear half of the polystyrene base pack.

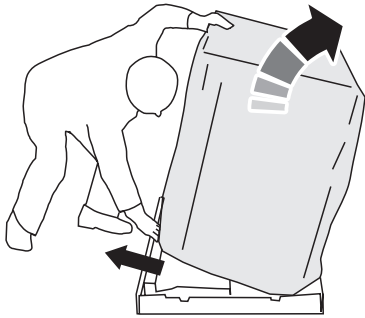

Repeat from the front and remove the front half of the poly base.

LOWER THE TWO REAR ROLLERS.

First fit the levelling tool on the hexagonal adjusting nut as shown below.

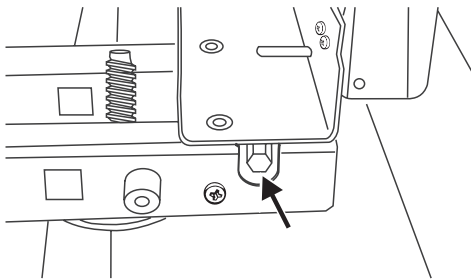

Make 10 complete (360°) turns clockwise. (This means turning and removing the levelling tool 20 times).

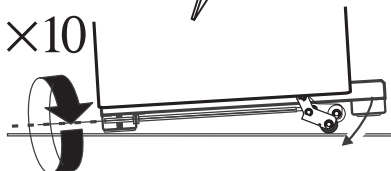
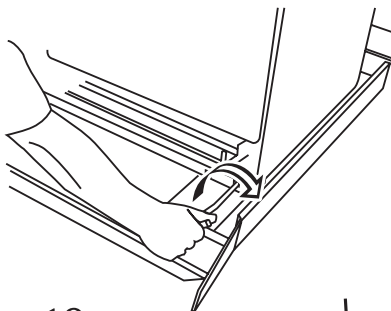

Make sure you lower BOTH REAR ROLLERS. There are two adjusting nuts, one for each roller, at both the front bottom corners of the cooker. Open the grill door and the Tall oven door. Grip under the fascia panel and lift the front of the cooker.

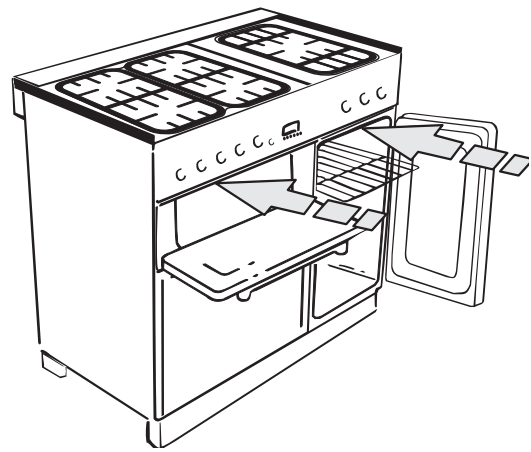

Carefully push the cooker backwards close to its final position leaving just enough space to get behind it. Take care not to damage the power cable.

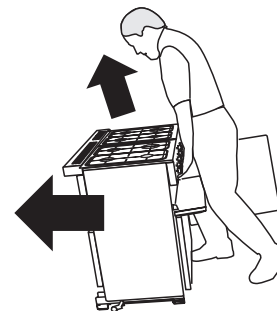

Do not use the door handles or control knobs to manoeuvre the cooker. Use the hotplate and griddle bowl areas. Remove the pack base tray.

Levelling

You are recommended to use a spirit level on a shelf in one of the ovens to check for level.

Place the cooker in its intended position taking care not to twist it within the gap between the kitchen units as damage may occur to the cooker or the units.

The front feet and rear rollers can be adjusted to level the cooker. To adjust the height of the rear of the cooker use the levelling tool supplied to turn the adjusting nuts at the front bottom corners of the cooker. To set the front feet turn the bases to raise or lower.

Fitting a stability bracket

A stability bracket or chain (**not supplied with the cooker**) should be fitted when the cooker is connected to a flexible gas supply.

When fitting a stability bracket read these instructions together with the leaflet supplied with the bracket.

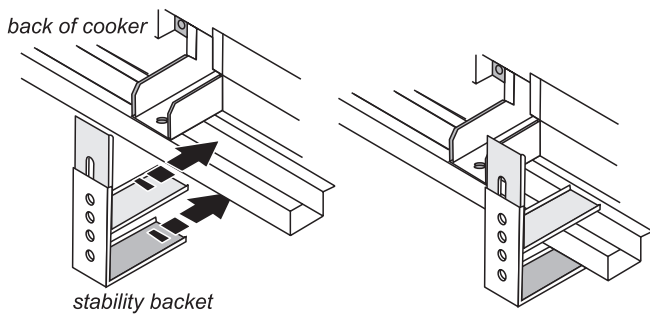
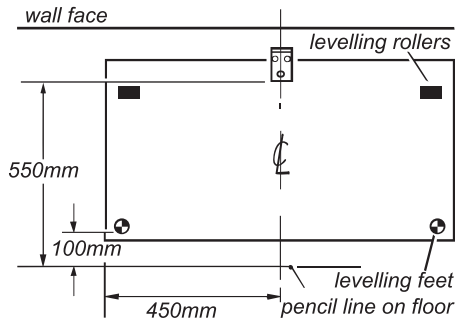

1. Place the cooker in its intended position and level the cooker.
2. Draw a pencil line 100mm from the front edge of the levelling feet.
3. Mark the centre line for the bracket by measuring 450mm from the left hand side of the cooker.
4. Lower front roller and move cooker forward.
5. Measure back from pencil line 550mm to locate front edge of the bracket. Fix the bracket to the floor.
6. Measure the height from floor level to engagement edge in back of cooker. Add 3mm to this dimension and assemble the stability bracket to this height. (i.e. from floor level to underside of the top member) and ensure the bracket does not foul the oven burner assembly.

Gas Connection

The Gas supply needs to terminate with a down facing bayonet. The rear cover boxes limit the position of the supply point.

Because the height of the cooker can be adjusted and each connection is different it is difficult to give precise dimensions. Ideally the house supply bayonet should be in the shaded area shown in the diagram. Although a 900mm hose can be used, a 1250mm hose will allow slightly more flexibility in the positioning of the bayonet and make moving the cooker easier. The hose should be fitted so that both inlet and outlet connections are vertical so that the hose hangs downwards.

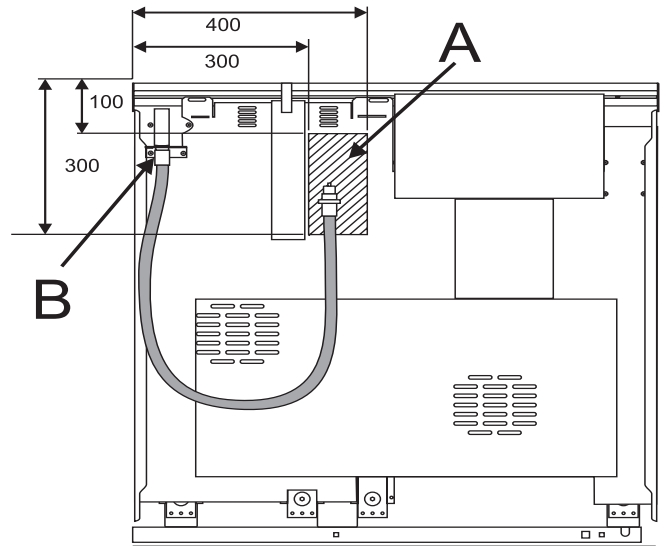

view from the rear

- A position for gas supply connector
- B appliance gas inlet

The connector is located just below the hotplate level at the rear of the cooker.

For Natural Gas the flexible hose must be in accordance with B.S.669.
For LP Gas it should be capable of 50mbar pressure, 70°C temperature rise and carry a red stripe, band or label.

If in doubt contact your supplier.
Screw connect the threaded end of the hose into the gas inlet in the underside of the connector block on the back of the cooker.
After completing the gas connection, check the cooker is gas sound with a pressure test. When checking for gas leaks do not use washing up liquid - this can corrode. Use a product specifically manufactured for leak detection.

Pressure testing

The gas pressure can be measured at the injector of one of the LH hotplate burners. Remove the pan support, burner head and caps. The injector is now accessible.

For Natural Gas cookers the pressure should be 20mbar.

For LP Gas cookers the pressure should be
29mbar for Butane
37mbar for Propane.

Reassemble burner top, making sure it is reassembled in the correct way on the burner body.

Electrical Connection

WARNING: THIS COOKER MUST BE EARTHED.

All external wiring must comply with the IEE Regulations for the Electrical Equipment of Buildings. Connection to the electrical supply can be made with either a plug and socket or be permanently wired via a double pole switch. The cooker is supplied with a 3 core cable 2m long. If a replacement cable is fitted it must be 250v high temperature PVC (85°C), 1mm². Should the plug not fit the socket in your home, it should be removed and replaced with a suitable plug. Note: If a plug is fitted which is not suitable, it must be cut off and disposed of properly. To avoid the risk of electrocution, the plug must not be left where children might find it and plug it into a supply socket.

Three pin plugs to BS1363 with a capacity of not less than 13A must be used and fitted with a 13 amp fuse 'ASTA' approved to BS 1362.

After replacing the fuse the cover must be refitted. If the cover is lost, the plug must not be used until a replacement cover has been obtained from your supplier. The colour of the correct fuse carrier is that of the coloured insert in the base of the fuse recess, or stated elsewhere on the plug. Always state this colour when ordering a replacement fuse carrier.

IMPORTANT The wires in the mains lead are coloured in accordance with the following code:-

GREEN AND YELLOW: EARTH

BLUE: NEUTRAL

BROWN: LIVE

The wires should be connected into the terminal of your plug as shown:

NEUTRAL: to the terminal marked N, or coloured BLACK or BLUE.

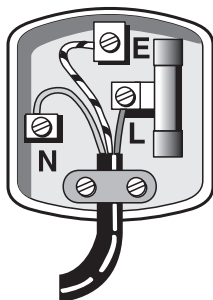

EARTH: to the terminal marked E, or coloured GREEN or GREEN /YELLOW.

LIVE: to the terminal marked L, or coloured RED or BROWN.

Electrical checks

EARTH CONTINUITY CHECK

The cooker must be disconnected from the power supply. Set your meter to Ω (ohm) on the X1 scale and adjust to zero if necessary.

Test the leads from any of the cooker's earth points (e.g. inside electric box cover) - to the earth pin on the cooker's plug - resistance should be less than 1 Ω (ohm). If it is not, check all the earth wires for continuity. Check that all contacts are clean and tight. Re-check. If the resistance is still greater than 1 Ω (ohm) there may be a problem, consult a qualified electrical engineer.

POLARITY CHECK

The cooker must be connected to the power supply. Your meter should be set on 300V ac scale.

Test at the cooker terminal block:

1. Test leads from L to N. Your meter should read approx. 220-240V ac.
2. Test leads from L to E. Your meter should read approx. 220-240V ac.
3. Test leads from N to E. Your meter should read approx. 0-15V ac.

If the readings are different from these values there is an electrical fault. Rectify any fault and repeat the test. If necessary repeat the test at the supply system socket/spur - if the fault also occurs at this stage then there is a house system fault which requires attention by the Electrical Authority.

The customer should be warned NOT to use the appliance until this examination has been carried out.

Grill check

Open the grill compartment door.

Natural gas models

Press in the grill knob, turn to the large flame symbol (♠) and press the igniter button or light with a match.

LP gas models

LP gas models have an FSD with stops the flow of gas to the grill if the flame goes out. Turn the knob to the large flame symbol (♠). Press in the grill knob. This lets gas through to the burner. Keep holding the knob pressed in and press the igniter button or light with a match. Keep holding the button for about 10 seconds

If when you let go of the control knob the burner goes out, the safety device has not held in. Turn off the grill and wait one minute then try again this time holding in the button for slightly longer.

Hotplate check

Check each burner in turn. Push in each knob and turn it to the large flame symbol. Press the IGN button, release the button when the burner lights.

Fitting the oven burner trim (main gas oven only - supplied with some models only)



The loose oven burner trim hooks onto the front of the oven burner bracket.

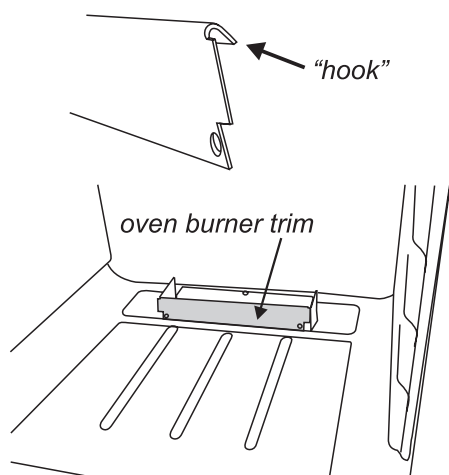

Main Oven check

The clock must be set to the time of day before the ovens will work.

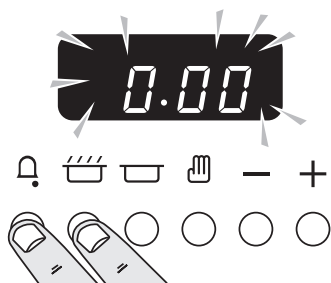

Press and hold as above.

At the same time, press - or + until the correct time shows.

Don't forget it's a 24 hour clock.

If you make a mistake or press the wrong button, turn off the power supply for a minute or two and start again.

CONTROL KNOB (THERMOSTAT) CHECK

If (AUTO) is flashing, press and release the manual (🔥) button. Check each oven in turn. Push in and turn the control knob to Mark 9. A series of sparks will occur at the oven electrode and when the oven burner lights the sparking will stop. A small flame will appear on the oven burner, but as this flame is 'sensed' by the flame supervision device, the gas flow will come on full after a short delay. Heat each oven for 10 minutes at Mark 9 then turn to Mark 1 and check that the flame size has reduced. Turn off each oven and check that the oven burner goes out.

TIMER AND SOLENOID CHECK

Automatic Operation of Timer: The gas supply to each oven can be controlled by the timer. Set a 'cooking period' time by pressing and releasing the (🕒) button and using the + button to give a time of 2 minutes. By pressing and releasing the 'stop time' button (⏸) the stop time is displayed. Add 3 minutes to this time by using the + button. The display will automatically change to show the time of day, the cooking symbol (🔥) will go out and (AUTO) will show.

Push in and turn one of the oven knobs to Mark 9, the timer will run until the 'cook period' starts, when the oven solenoid will open and the burner will light automatically. The cooking symbol (🔥) will show. At the end of the 'cooking period' the solenoid will close, the oven burner will go out and the beeper will sound (the beeper may be stopped by pressing the timer (🕒) button). The flashing (AUTO) symbol is a reminder to reset to manual operation. Pressing the reset' button (🔥) once to stop the beep and a second time to return to manual, turn off the oven knob.

CONTROL KNOB (THERMOSTAT) CHECK

Set timer to manual. Check each oven in turn. Push in and turn the control knob to Mark 9. A series of sparks will occur at the oven electrode and when the oven burner lights the sparking will stop. A small flame will appear on the oven burner, but as this flame is 'sensed' by the flame supervision device, the gas flow will come on full after a short delay. Heat each oven for 10 minutes at Mark 9 then turn to Mark 1 and check that the flame size has reduced. Turn off each oven and check that the oven burner goes out.

Tall oven

Turn on the Tall oven and check that it heats up.

Fitting the plinth

Loosen the 3 screws along the front bottom edge of the cooker. Hook the central keyhole over the central screw. Twist and fit each end keyhole over their respective screws. Tighten the fixing screws.

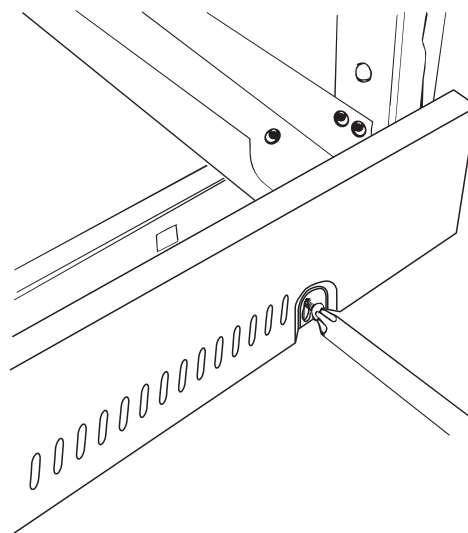

Customer care

Please complete your details in the inside cover of this Guide. Then replace this Installation Guide back in the Customer Care Pack in the correct position. Please inform the user how to operate the cooker and hand over the Customer Care Pack.

Thank you.

Circuit Diagram

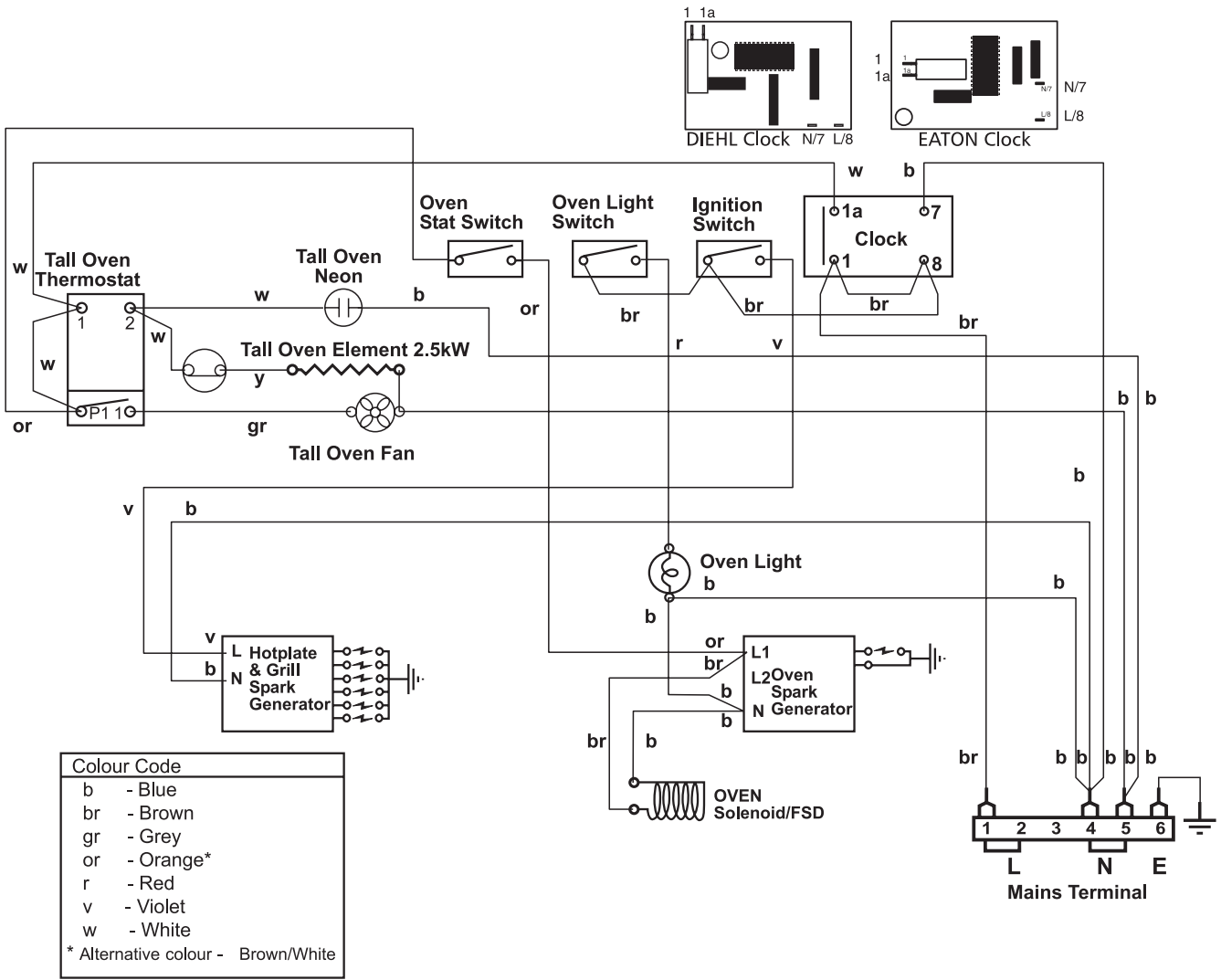

Technical Data

This cooker is designed for use on either :-

NATURAL GAS (Cat I2H) at 20mbar or

LP GAS (Cat I3+) Butane 29mbar / Propane 37mbar.

NB: THE NATURAL GAS AND LP GAS VERSIONS OF THESE COOKERS ARE DIFFERENT MODELS AND **CANNOT** BE CONVERTED FROM ONE GAS FAMILY TO THE OTHER.

INSTALLER: Please leave these instructions with the User.

DATA BADGE LOCATION: Cooker back, serial number repeater badge below oven door opening.

Country of Destination: GB/IE

Gas		Electric
Natural Gas	20mbar	220 - 240V 50Hz
Butane	29mbar	
Propane	37mbar	

(See appliance data badge for test pressures)

Dimensions

Overall height	minimum 893mm maximum 920mm
Overall width	900mm See 'Positioning of Cooker'
Overall depth	648mm
Space for fixing	See 'Positioning of Cooker'
Minimum space above hotplate	650mm

Connections

Gas:	Electric
Rp 1/2 at rear right-hand side	220 - 240V 50Hz

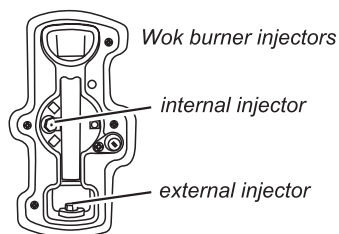

Ratings

	Natural Gas		L.P. Gas	
		Injector		Injector
Hotplate				
Wok burner	3.5kW	internal 80 external 129	3.5kW(246g/h)	internal 54 external 77
Large Burner	3.0kW	134	3.0kW (210g/h)	87
Medium Burners	1.7kW	109	1.7kW (119g/h)	68
Small Burner	1.0kW	75	1.0kW (70g/h)	51
Main Oven	3.2kW	237	2.9kW (224g/h)	85
Tall Oven (electric)	2.5kW		2.5kW	
Grill	2.73kW	190	2.73kW (192g/h)	85
Gas burner inputs based on Gross Calorific Value				
Total electrical load 2.6kW approx.				

RANGEmaster

Clarence Street, Royal Leamington Spa,
Warwickshire, CV31 2AD, England.
Tel: +44 (0) 1926 457400 Fax: +44 (0) 1926 450526
E-mail: consumers@rangemaster.co.uk
www.rangemaster.co.uk

AGA FOODSERVICE GROUP